

GLASS MANUFACTURING

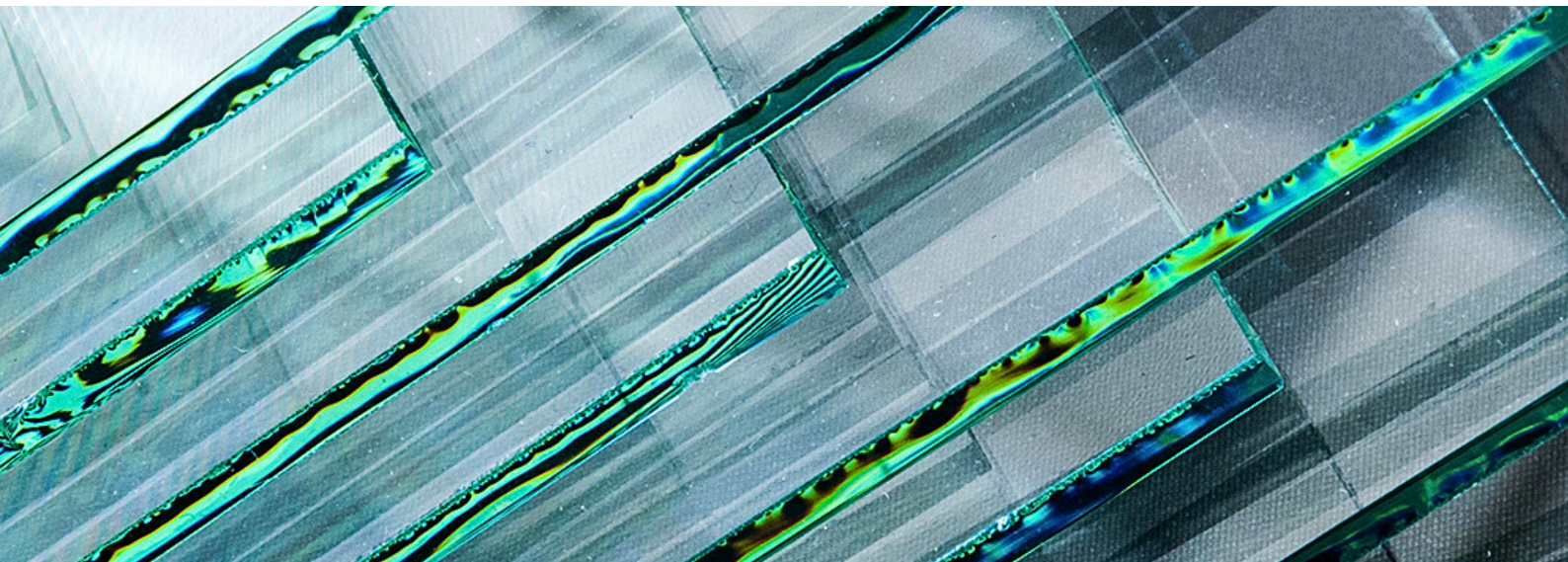

Benefit

from our technology

- ✔ Maximise Furnace Performance & Pull Rate
- ✔ Significant Energy Savings & Emission Reduction
- ✔ Improved Glass Quality & Operational Flexibility
- ✔ Expert Solutions Tailored to Your Process

The Industry Challenge

In today's competitive landscape, glass producers face significant pressures. Rising fuel costs, stringent environmental regulations, and the need to maintain production output especially with aging furnaces present substantial obstacles. Hence, optimizing the glass-melting process is critical to overcoming these challenges, ensuring both profitability and a sustainable future.

The Nexelia™ Solution for Glassmaking



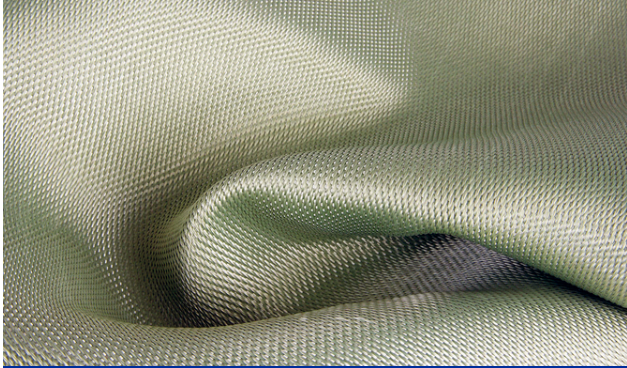

Nexelia™ for Glassmaking is a comprehensive gas solution **designed to meet your specific needs**. It combines our industry-leading supply of industrial gases, patented application technologies, and the full support of our expert teams. We work closely with you to pre-define a concrete set of results and commit to delivering them. By replacing air with pure oxygen in the combustion process, Nexelia™ enhances heat transfer, leading to superior efficiency, reduced emissions, and improved final product quality across all your key processes.



Melting OXY-COMBUSTION

Nexelia™ for Melting Oxy-Combustion **uses pure oxygen** instead of air. This eliminates nitrogen from the furnace, dramatically improving heat transfer and optimizing the glass-melting process. It is well suited for all types of glass, including insulation glass, reinforcement fiber, lighting glass and other technical and container glass.

Key Advantages

-  Up to 50% energy savings
-  Up to 90% nox savings
-  Enhanced furnace efficiency
-  Reduction in Capex

1



GLASS MELTING BURNER-FC

Patented design mixes fuel & oxygen externally then uses unique injectors to produce a hugely luminous flame up to 3x wider than conventional oxy-fuel burners.

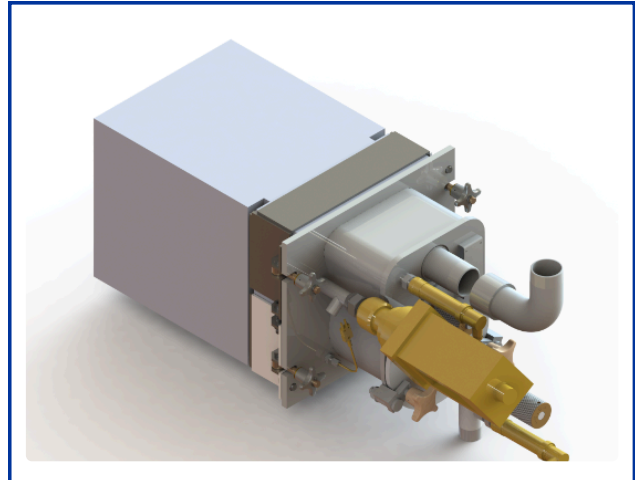

Case Study



Fiberglass

Air-recuperative furnace 30 tpd
Reinforcement Fiberglass



CUSTOMER NEEDS

Improve combustion efficiency, cost effectiveness and reduce NOx emissions



SOLUTION

Conversion to full oxy-combustion furnace



BENEFITS

Fuel savings = 41%
Yearly operating cost savings = 6 %
CO2 reduction = 41%
Flue gas reduction = 82%

Patented Burner Technologies



GLASS MELTING BURNER

Non-water-cooled oxy-fuel burner specially designed for continuous melting furnaces. Appropriate for most glass types.

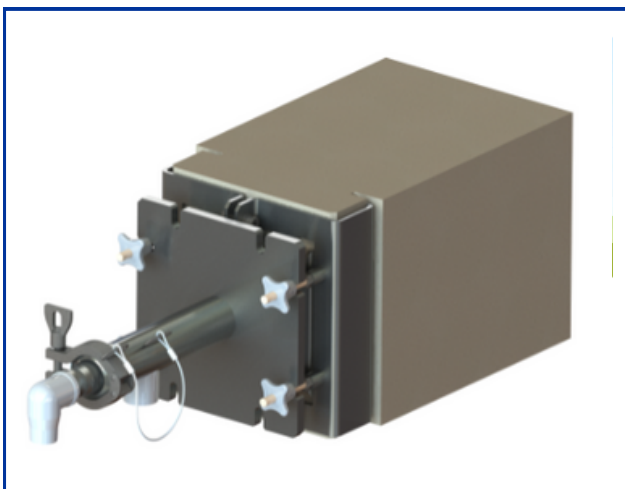

VALVE TRAINS

Automated control system to monitor the oxy-fuel burners and their supply systems.

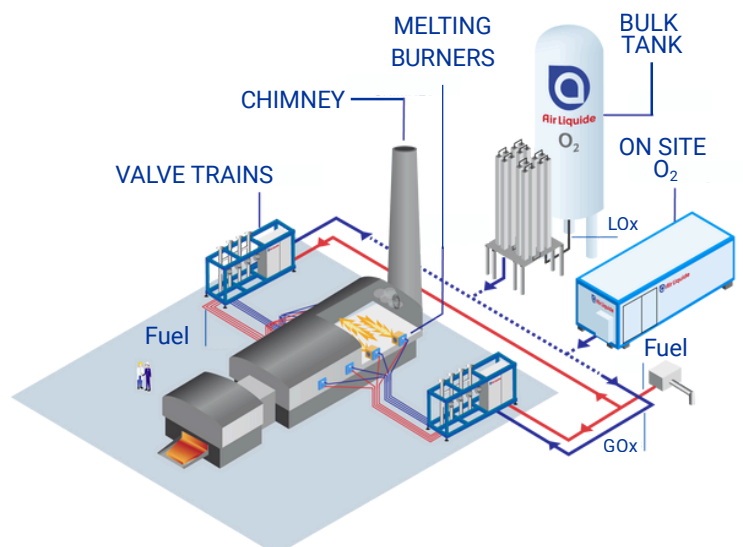





Melting OXY-BOOSTING

Nexelia™ for Melting Oxy-Boosting is the ideal solution to compensate for furnace aging and increase production. By strategically adding pure oxygen to your existing air-combustion process, you can significantly boost heat transfer, maintain performance, and extend your furnace's campaign life.

Key Advantages

-  Pull increases up to 10%
-  Furnace life time extension
-  Efficient services & equipments

2



GLASS MELTING BURNER-FC

Patented design mixes fuel & oxygen externally then uses unique injectors to produce a hugely luminous flame up to 3x wider than conventional oxy-fuel burners.

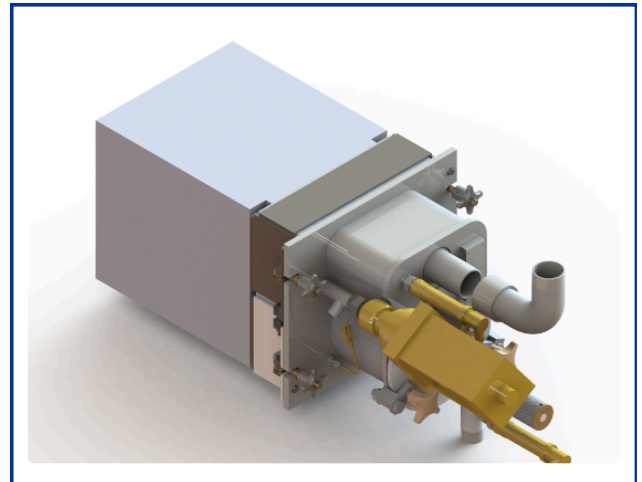

Case Study



BOTTLE

Regenerative, end-port furnace 360 tpd soda lime



CUSTOMER NEEDS

Maintain production and quality facing regenerator difficulties because of degraded regenerator and loss of efficiency.



SOLUTION

Partial loss of combustion air compensated by oxygen injection with two lances per side.



BENEFITS

Furnace campaign extended a full year.

Patented Burner Technologies



GLASS MELTING BURNER

Non-water-cooled oxy-fuel burner specially designed for continuous melting furnaces. Appropriate for most glass types.

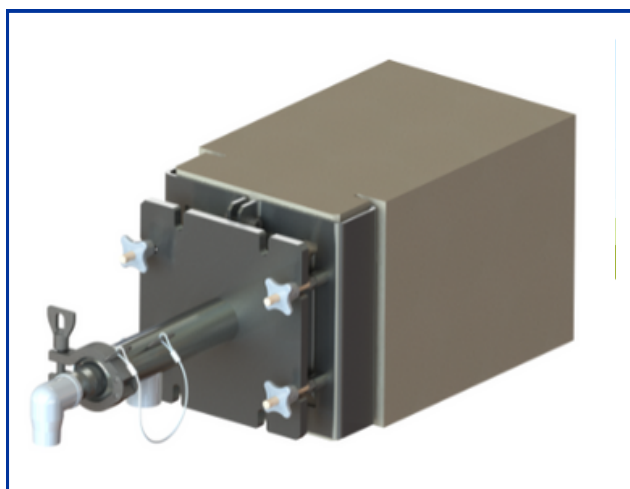

VALVE TRAINS

Automated control system to monitor the oxy-fuel burners and their supply systems.

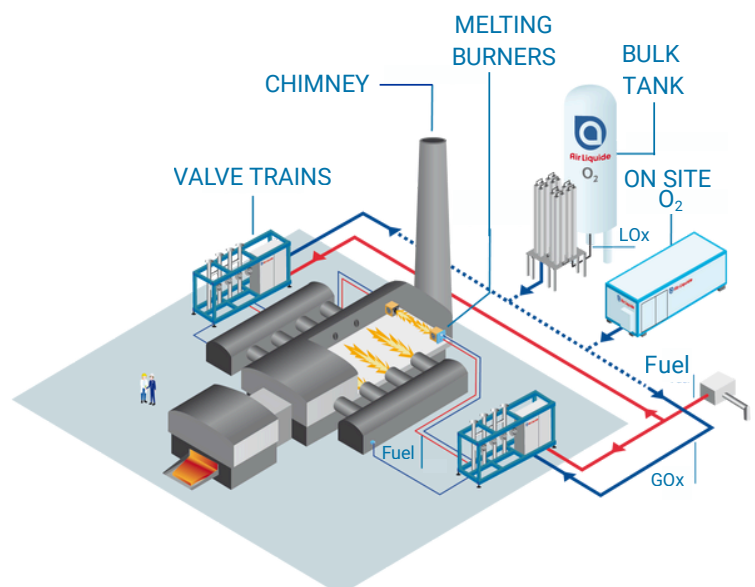







Melting Heat OXY-COMBUSTION

Nexelia™ for Melting-Heat Oxy-Combustion uses a unique and patented system to preheat the oxygen and natural gas using heat recovered from the combustion fumes. This maximises thermal efficiency, making it economically beneficial for all glass types, including container, technical, and float glass.

Key Advantages

-  **10% Extra energy savings**
-  **10% Extra CO₂ emission reduction**
-  **Lower pollutant emissions**
-  **Maximising oxy-combustion performance**

3

Case Study

FLOAT GLASS

CAPEX = €4.25 million

Solutions	Burning O ₂ without preheating	Burning Preheated O ₂ and fuel
Fuel (€/y)	12,300	11,070
Oxygen (€/y)	3,867	3,481
Capex-linear depreciation (10y)(€/y)		425
Licensee Fees (€/y)		95
Total (€/y)	16,167	15,071
Total savings (€/y)		1,096
Total savings (%)		7

→ Savings: €M 1.096 per year

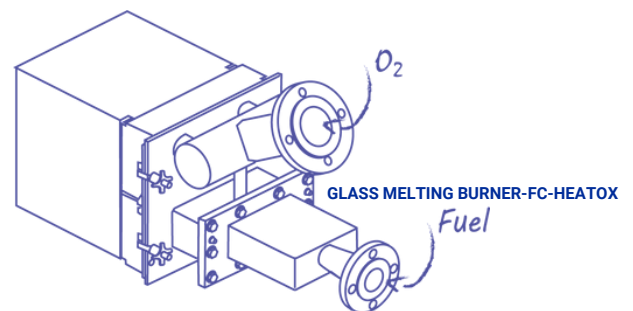
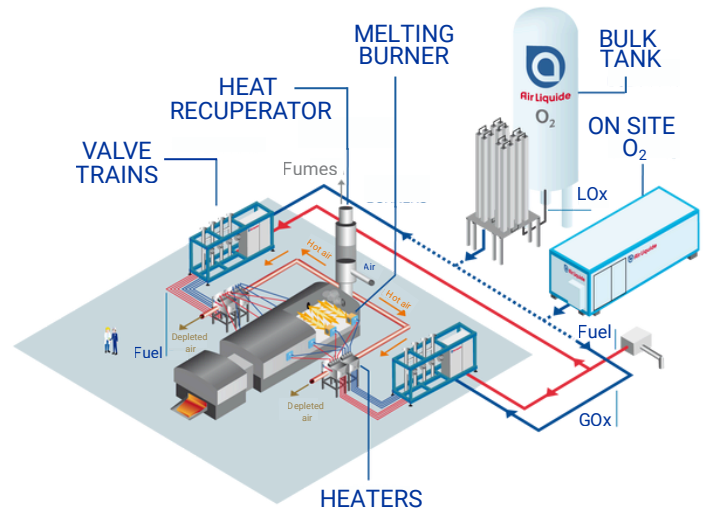

Patent Burner Technologies

GLASS MELTING BURNER-FC-HEATOX

It is a patented non-water-cooled oxy-fuel burner for technical and containers glass-type applications.

GLASS MELTING BURNER-SUN-HEATOX

It is a patented non-water-cooled oxy-fuel burner for large furnace, such as those that use float glass-type production.

VALVE TRAINS

Automated control system to monitor the oxy-fuel burners and their supply systems.

YOU GET FULL SUPPORT

Our experts provide full support at every step, from the auditing of your current melting process to the detailed designs of your new solution, & its complete implementation. All our technologies are easily and reliably installed by our teams.

Proven technology with references

We have several references operating with HEATOX

- Float Glass
- Container Glass
- Tableware Glass

Contact us

Air Liquide Indonesia

+62 21 50845460

marketing.indonesia@airliquide.com

Jl.Sulawesi Blok I No. 1-2,

MM2100 Industrial Town,

Gandamekar, Kec. Cibitung,

Kabupaten Bekasi, Jawa Barat 17530

www.id.airliquide.com

